

EVAPORATIVE COOLING SYSTEMS

INFINITY SERIES

IDD-1XXX-AFXX

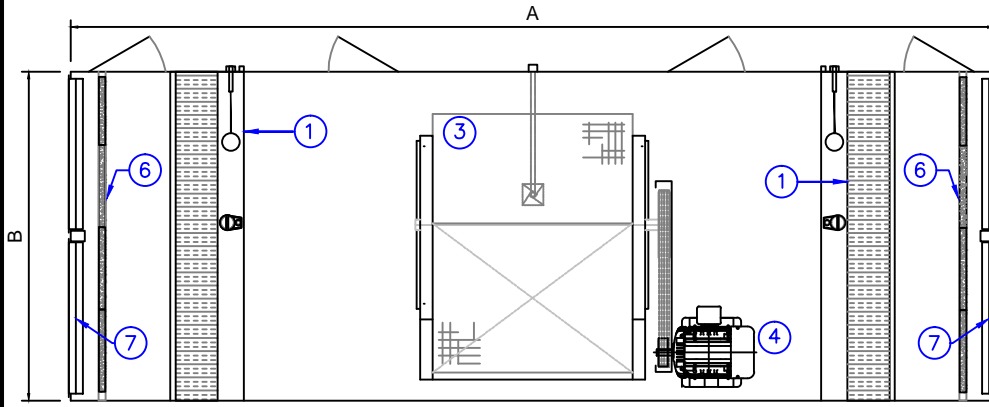
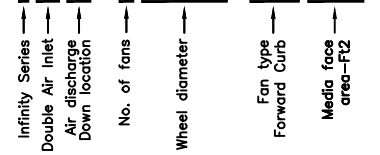

INTERNAL PLAN VIEW

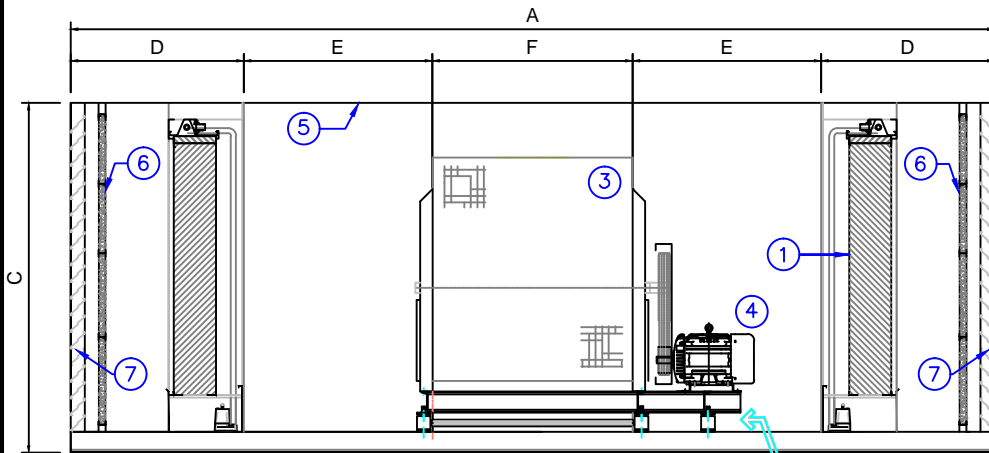

FRONT ELEVATION

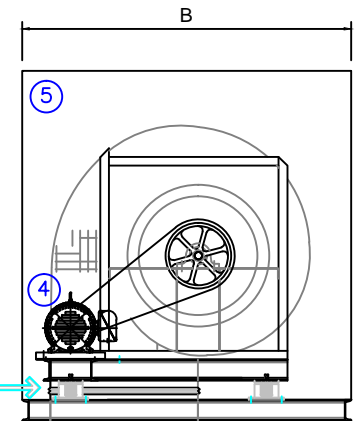

SIDE CROSS SECTION

MODEL	Std. CFM	ISP"	ESP"	TSP"	BHP/HP	A	B	C	D	E	F	G	H
IDD-1 40 AF 94	45,000	0.70	0.70	1.40	20.1 / 25	22'- 0"	7'-10"	8'- 4"	49 1/2"	53 7/8"	57 1/4"	42 3/4"	8"
IDD-1 44 AF 94	45,000	0.70	0.70	1.40	16.89 / 20	22'- 0"	7'-10"	8'- 4"	49 1/2"	50 7/8"	63 1/4"	47 1/4"	7"
IDD-1 44 AF 100	50,000	0.70	0.70	1.40	20.44 / 25	22'- 0"	8'- 4"	8'- 4"	49 1/2"	50 7/8"	63 1/4"	47 1/4"	8"
IDD-1 44 AF 108	55,000	0.70	0.70	1.40	24.57 / 30	22'- 0"	9'- 0"	8'- 4"	49 1/2"	50 7/8"	63 1/4"	47 1/4"	8"
IDD-1 49 AF 108	55,000	0.70	0.70	1.40	20.76 / 25	23'- 4"	9'- 0"	8'-11"	52 1/2"	52 3/4"	69 1/2"	52 1/4"	8"
IDD-1 44 AF 118	60,000	0.70	0.70	1.40	29.31 / 30	22'- 0"	9'- 10"	8'- 4"	49 1/2"	50 7/8"	63 1/4"	47 1/4"	10"
IDD-1 49 AF 118	60,000	0.70	0.70	1.40	24.31 / 30	23'- 4"	9'- 10"	9'- 6"	52 1/2"	52 3/4"	69 1/2"	52 1/4"	10"
IDD-1 49 AF 138	65,000	0.70	0.70	1.40	28.32 / 30	23'- 4"	9'- 10"	9'- 6"	52 1/2"	52 3/4"	69 1/2"	52 1/4"	10"
IDD-1 54 AF 138	70,000	0.70	0.70	1.40	27.23 / 30	23'-10"	9'- 10"	9'- 10 1/2"	52 1/2"	52"	77"	57 3/8"	10"
IDD-1 54 AF 157	75,000	0.70	0.70	1.40	30.93 / 40	23'-10"	9'- 10"	10'- 4"	52 1/2"	52"	77"	57 3/8"	10"
IDD-1 54 AF 157	80,000	0.70	0.70	1.40	35.0 / 40	23'-10"	9'- 10"	10'- 4"	52 1/2"	52"	77"	57 3/8"	10"



BARNHART-TAYLOR, INC.
 AIR HANDLING AND
 EVAPORATIVE COOLING SYSTEMS
**INFINITY SERIES
 EVAPORATIVE COOLERS**

IDD SERIES UNITS-GENERAL LAYOUT

NOTES:

- 1- BLOWER AMCA CLASS I OR CLASS II, AIRFOIL WHEEL, PERMATECTOR COATED.
- 2- CONTACT US FOR DIFFERENT EXTERNAL STATIC PRESSURE (ESP) FOR MOTOR SELECTIONS.
- 3- DRAWING NOT FOR CONSTRUCTION PURPOSES
- 4- BHP INCLUDES BELT LOSSES

ITEM	QTY	DESCRIPTION
1	2 sets	EVAPORATIVE COOLING MEDIA MUNTERS CELDEK 12" THICK
2	2	CIRCULATION PUMPS: LITTLE GIANT WGP
3	1	SUPPLY FAN: GREENHECK DWDI AIRFOIL
4	1	PREMIUM EFFICIENCY MOTOR 230V / 460V / 3ø / 60HZ TEFC
5	1	FAN CASING - GALVANNEAL SHEET METAL GAUGE 18
6	1	2" FILTERS - AAF PERFECT PLEAT HC
7	1	4" DEEP DRAINABLE LOUVERS - GALVANNEAL STEEL METAL

DRAWING No:
IUS-10017-R1
 DATE: 11/15/2012