

# EVAPORATIVE COOLING SYSTEMS

## INFINITY SERIES

### ISS-2XXXX-FCXX

↑ Infinity Series  
 ↑ Single Air Inlet  
 ↑ Air discharge Top location  
 ↑ No. of fans  
 ↑ Wheel diameter  
 ↑ Wheel width  
 ↑ Fan type Forward Curb  
 ↑ Media face area-Ft2

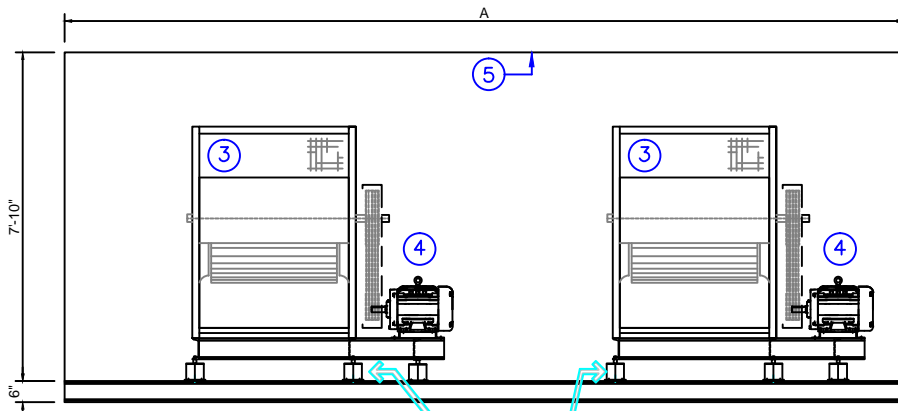
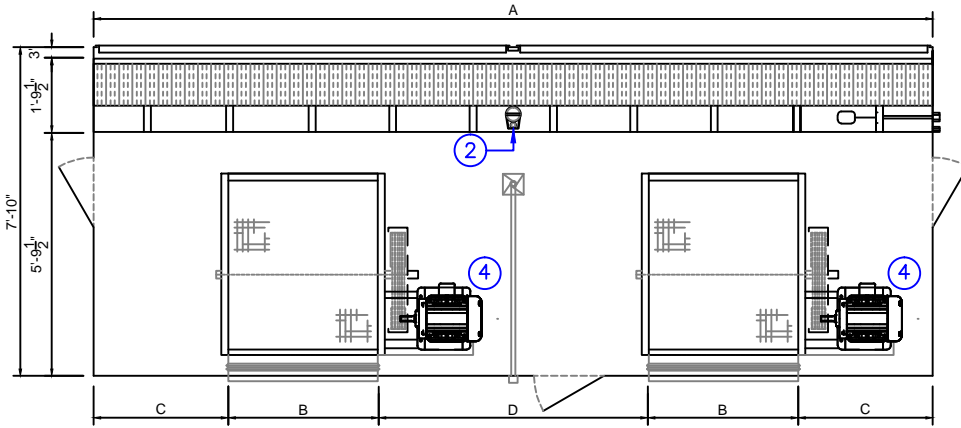

OPTIONAL VIBRATION ISOLATORS

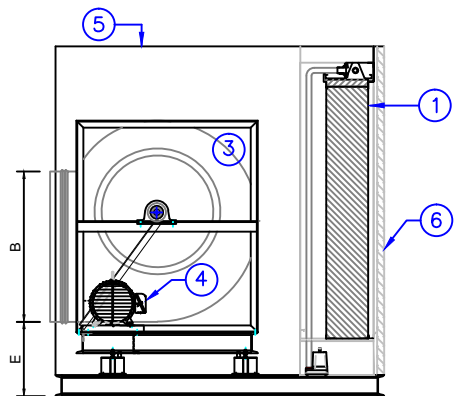

MODEL	Std. CFM	ISP"	ESP"	TSP"	BHP/HP	A	B	C	D	E
ISS-23030-FC78	40,000	0.35	0.70	1.05	6.4 / 7.5	13'	37"	24"	34"	22"
ISS-23030-FC84	42,500	0.35	0.70	1.05	7.1 / 7.5	14'	37"	26"	42"	22"
ISS-23030-FC90	45,000	0.35	0.70	1.05	7.9 / 10	15'	37"	30"	46"	22"
ISS-23030-FC99	50,000	0.35	0.70	1.05	9.7 / 10	16'	37"	32"	54"	22"
ISS-23636-FC102	50,000	0.35	0.70	1.05	8.0 / 10	16'	43"	32"	42"	22"
ISS-23030-FC105	52,500	0.35	0.70	1.05	10.7 / 15	17'	37"	32 1/2"	65"	22"
ISS-23636-FC105	52,500	0.35	0.70	1.05	8.7 / 10	17'	43"	32 1/2"	53"	20 1/2"
ISS-23030-FC108	55,000	0.35	0.75	1.10	12.1 / 15	18'	37"	35 1/2"	71"	22"
ISS-23636-FC108	55,000	0.35	0.70	1.05	9.5 / 10	18'	43"	32 1/2"	65"	20 1/2"
ISS-23636-FC108	57,500	0.35	0.70	1.05	10.3 / 15	19'	43"	35 1/2"	71"	20 1/2"
ISS-23636-FC120	60,000	0.35	0.70	1.05	11.2 / 15	20'	43"	38 1/2"	77"	20 1/2"
ISS-23636-FC126	62,500	0.35	0.70	1.05	12.2 / 15	21'	43"	41 1/2"	83"	20 1/2"
ISS-23636-FC132	65,000	0.35	0.70	1.05	13.2 / 15	22'	43"	44 1/2"	89"	20 1/2"
ISS-23636-FC138	70,000	0.35	0.70	1.05	15.4 / 20	23'	43"	47 1/2"	95"	20 1/2"
ISS-23636-FC144	72,500	0.35	0.75	1.10	16.9 / 20	24'	43"	50 1/2"	101"	20 1/2"
ISS-23636-FC150	75,000	0.35	0.80	1.20	18.9 / 20	25'	43"	53 1/2"	107"	20 1/2"
ISS-23636-FC159	80,000	0.35	1.05	1.40	23.2 / 25	26'	43"	56 1/2"	113"	20 1/2"



**BARNHART-TAYLOR, INC.**  
 AIR HANDLING AND  
 EVAPORATIVE COOLING SYSTEMS  
**INFINITY SERIES**  
 EVAPORATIVE COOLERS

#### ISS SERIES UNITS-GENERAL LAYOUT

##### NOTES:

- 1- BLOWER AMCA CLASS 1, HOT DIP GALVANIZED WHEEL, CLASS II AVAILABLE.
- 2- CONTACT US FOR DIFFERENT EXTERNAL STATIC PRESSURE (ESP) FOR MOTOR SELECTIONS.
- 3- DRAWING NOT FOR CONSTRUCTION PURPOSES
- 4- BHP INCLUDES BELT LOSSES

ITEM	QTY	DESCRIPTION
1	1 set	EVAPORATIVE COOLING MEDIA MUNTERS CELDEK 12" THICK
2	1	CIRCULATION PUMPS; LITTLE GIANT WGP
3	1	SUPPLY FAN; LAU INDUSTRIES H SERIES
4	1	PREMIUM EFFICIENCY MOTOR 230V / 460V / 3ø / 60HZ TEFC
5	1	FAN CASING - GALVANNEAL SHEET METAL GAUGE 18
6	1	2" DEEP LOUVERS - GALVANNEAL STEEL METAL

DRAWING No:

**IUS-10016-R1**

DATE: 3/15/2013