

EVAPORATIVE COOLING SYSTEMS

PENTHAIRE SERIES

PSS-1XX-AFPLN-XX

- ↑ Penthaire Series
- ↑ Single Inlet
- ↑ Air discharge Side location
- ↑ No. of Blowers
- ↑ Size of Blower 60" Diameter
- ↑ Type of Blower Air Foil Design
- ↑ Horizontal Plenum Fan
- ↑ Evap Media Face Area 79 Sq. Ft.

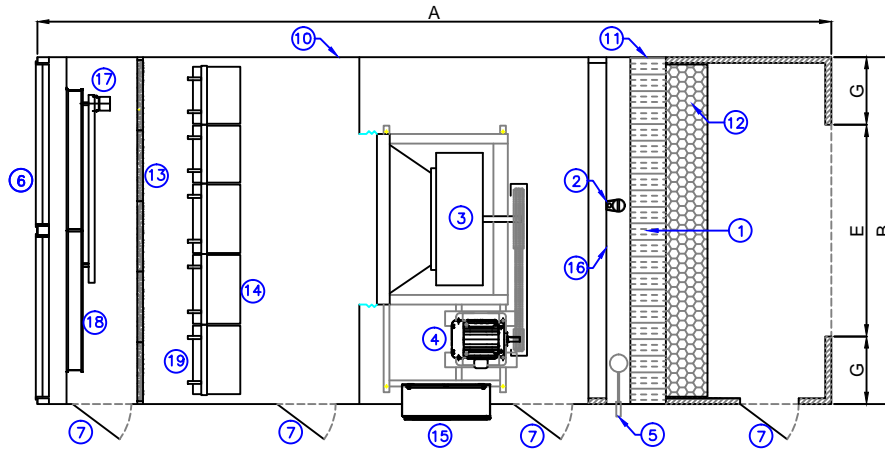

INTERNAL PLAN VIEW

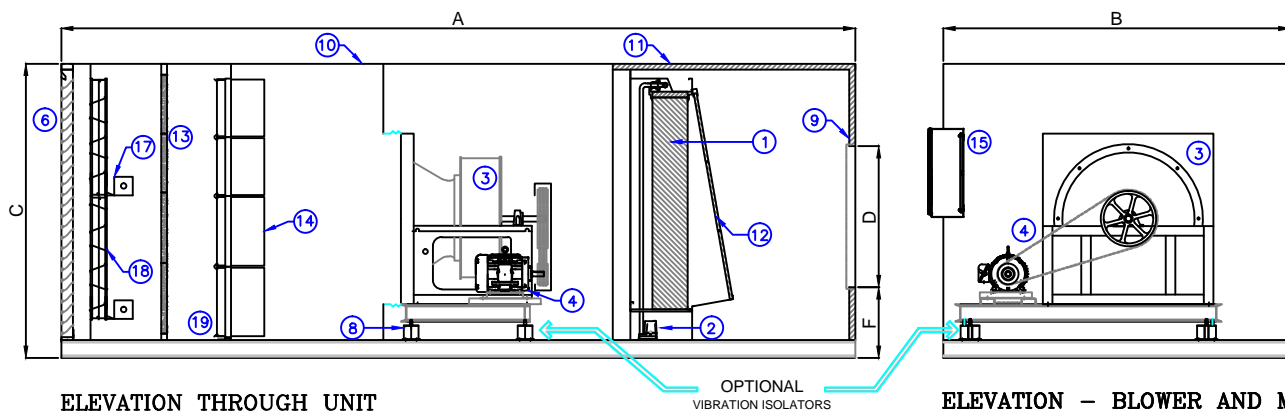

ELEVATION THROUGH UNIT

ELEVATION - BLOWER AND MOTOR

MODEL	Std. CFM	ISP"	ESP"	TSP"	BHP/HP	A	B	C	D	E	F	G
PST-140-AFPLN-47	25,000	1.6	1.0	2.6	15.15 / 20	22'-0"	7'-10"	8'- 4"	4'-0"	5'-0"	2'-0"	1'-5"
PST-144-AFPLN-59	30,000	1.6	1.0	2.6	18.09 / 20	22'-6"	9'-10"	8'- 4"	4'-0"	6'-0"	2'-0"	1'-11"
PST-149-AFPLN-69	35,000	1.6	1.0	2.6	20.94 / 25	23'-4"	9'-10"	9'- 4"	4'-6"	6'-6"	2'-6"	1'-8"
PST-154-AFPLN-79	40,000	1.6	1.0	2.6	23.69 / 25	24'-0"	9'-10"	10'- 4"	5'-0"	7'-0"	2'-6"	1'-5"
PST-154-AFPLN-90	45,000	1.6	1.0	2.6	27.17 / 30	25'-2"	15'-0"	8'- 4"	4'-0"	9'-6"	2'-0"	2'-9"
PST-160-AFPLN-100	50,000	1.6	1.0	2.6	29.67 / 30	25'-2"	12'-6"	10'- 4"	5'-0"	7'-10"	2'-6"	2'-4"
PST-160-AFPLN-110	55,000	1.6	1.0	2.6	33.18 / 40	25'-2"	13'-9"	10'- 4"	5'-0"	9'-10"	2'-6"	1'-11 1/2"
PST-160-AFPLN-120	60,000	1.6	1.0	2.6	37.07 / 40	25'-2"	15'-0"	10'- 4"	5'-0"	9'-10"	2'-6"	2'- 7"

ITEM	QTY	DESCRIPTION	ITEM	QTY	DESCRIPTION
1	1 SET	MUNTERS CELDEK MEDIA 12" THICK.	11	1	AIR WASHER SECTION 18 GAUGE 304 STAINLESS STEEL
2	1	CIRCULATION PUMP 115V/1Ø LITTLE GIANT WGP SERIES	12	1 SET	MIST ELIMATOR - 1" ALUMINUM FILTERS BY AMERICAN AIR FILTERS
3	1	SUPPLY FAN GREENHECK AIR FOIL - PLENUM QEP SERIES	13	1 SET	2" WASHABLE ALUMINUM FILTER BY AMERICAN AIR FILTERS
4	1	MOTOR-SUPPLY FAN 460V/3Ø/60 HZ PREMIUM EFFICIENCY	14	1 SET	12" FILTERS BY AAF - VARICELL RF MERV 11, 12, 14 OR 15
5	1	PLUMBING: 3/4" SUPPLY, 2" OVERFLOW, 1" DRAIN FOR WET SECTION SUMP	15	1	MOTOR STARTER/ CONTROL PANEL, 1 OR 2 SPEED OR VFD, 480V/ 3Ø/ 60HZ.
6	1	4" DEEP LOUVERS DRAINABLE TYPE 20 GA. GALVANNEAL A-60 SHEET METAL	16	1	TIMED FLUSH PUMP 115V, 1"Ø, LITTLE GIANT WGP-65-PN
7	4	ACCESS DOORS-DOUBLE WALL, HEAVY DUTY HINGES AND LATCHES	17	1 SET	DAMPER MOTOR 115V/1Ø/60HZ FOR OUTSIDE AIR DAMPERS
8	1 SET	SEISMIC HDG VIBRATION ISOLATORS-AMBER BOOT AM SR (1" OR 2" DEFLECTION)	18	1 SET	6" OUTSIDE AIR DAMPER BY CESCO PRODUCTS; OPP. BLADE TYPE OR SIMILAR
9	1 SET	DOUBLE WALL LINER-304 STAINLESS STEEL SHEET METAL 22 GA.	19	1 SET	2" OR 4" THICK AMERICAN AIR FILTERS - PERFECTPLEAT MERV 8
10	1	FAN CASING 18 GAUGE A-60 GALVANNEAL SHEET METAL			



**PENTHAIRE
SERIES
EVAPORATIVE
COOLERS**

BARNHART-TAYLOR, INC.
EVAPORATIVE COOLING SYSTEMS

PSS SERIES UNITS-GENERAL LAYOUT

- NOTES:
- 1.-ISP INCLUDE WASHABLE FILTERS, 2' MERV 8 PRE-FILTERS AND 12' MERV 12 FINAL FILTERS.
 - 2.-UNITS ABOVE 40,000 CFM ARE SPLIT FOR SHIPPING
 - 3.-BHP INCLUDES BELT LOSSES.

DRAWING No:

IUS-10025-R1

DATE: 12/05/2012